

# IS

Ivan Olsen

for sinfonietta  
- score in transposition -

# - IS -

Ivan Olsen

Instr:

Flute  
Oboe  
Clarinet (Bb)  
Bassoon  
Horn

Percussion: Vibraphone (vibr.)  
Crotales (Crot.):



Bass drum (B.d.)  
Gongs:



Tubular bells (bells):



Medium/big Tam-tam (T.t.)  
Small Tam-tam (arco) (T.t)

Violin I & II  
Viola  
Cello  
Double bass

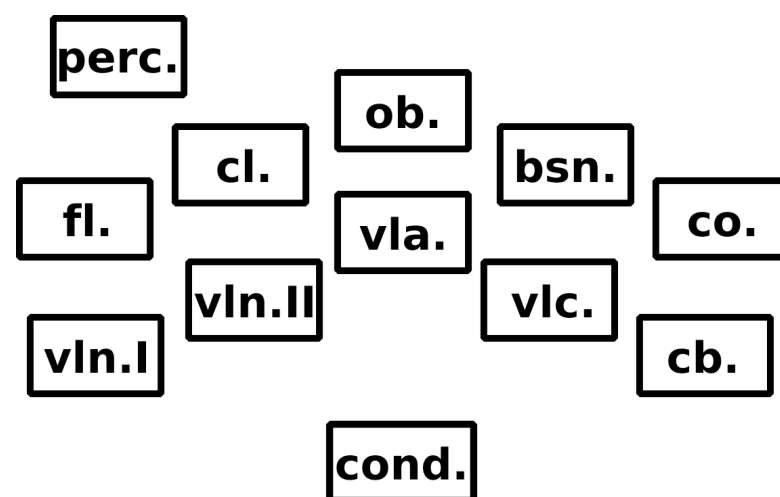

Notes for performance

All 5/8 = 2 + 3, and all 7/8 = 2 + 2 + 3

All tempo 40 – con rubato

Grace notes = anticipated (main note on the beat)

- Score in Transposition -



2 7

Fl. *pp* *p*

Ob. *p*

Cl. *mp* *p*

Bsn. *mf* *p* *sfz* *sfz*

Hn. *fiz. gestopft* (gestopft) *fiz. open*

Perc. *Crot. (hard vibr. triolata)* *B.d.* *ppp* *sfz* *mf* *mf* *mf*

Vln. I *gliss.* *p* (con sord.) *ppp* *mf* *mp* *pp*

Vln. II *p* (con sord.) *trem. am spitze* *pp* *mp* *pp*

Vla. *gliss.* *p* (con sord.) *trem. am spitze* *pp* *mp* *pp*

Vc. *gliss.* *p* (con sord.) *trem. am spitze* *pp* *mp* *pp*

Cb. *mp* *mf* *pp* *trem. am spitze* *pp* *mf* *f* *pizz.*

16

Fl. *mf* *p* *pp* *pp* *pp*

Ob. *p* *p* *pp* *pp* *pp*

Cl. *p* *pp* *pp* *pp*

Bsn. *p* *p* *pp* *pp*

Hn. *gestopft* *p* *open espr.* *mf*

Perc. *pp* *pont.* *T.t. (small) arco*

Vln. I *p* *ppp*

Vln. II *p* *ppp*

Vla. *mp* *p* *ppp*

Vc. *p* *ppp*

24

Fl. *pp*

Ob. *pp*

Cl. *pp*

Bsn. *pp*

Hn.

Perc. poco a poco from arco to mallets trem. mallets

Vln. I *mf* con sordin

Vln. II *pp* con sordin

Vla. *pp* con sordin

Vc. *pp* con sordin

Cb. arco *mf* espr.

33

Fl. *ppp*

Ob. *ppp*

Cl. *ppp*

Bsn. *ppp*

Hn. *pp* gestopft

Perc. gongs T.b. I.v.

Vln. I *pp* senza sordin

Vln. II *p* senza sordin

Vla. *pp* senza sordin

Vc. *pp* senza sordin

Cb. *p*

$\text{♩} = 80$



57 5

Fl. *mp*

Ob.

Cl.

Bsn. *pp*

Hn. *pp*

Perc. *mp*

Vln. I

Vln. II

Vla. *pp*

Vc. *pp*

Cb.

**D**  $\text{♩} = 40$  **E**  $\text{♩} = 80$

Fl. *p* *sim.*

Ob.

Cl. *p* *sim.*

Bsn. *p* *sim.*

Hn. *p* *gestopft* *sim.*

Perc. T.t. (medium/big) *p* *Vibr.* *pp* *senza sordin*

Vln. I *pp* *con sordin* *3* *senza sordin* *p* *sim.*

Vln. II *pp* *con sordin* *3* *senza sordin* *p* *sim.*

Vla. *p* *con sordin* *pp* *(con sord.)* *pp*

Vc. *p* *con sordin* *pp* *(con sord.)* *pp*

Cb. *p* *arco* *pp* *con sordin* *pp*

6 69

Fl.

Cl.

Bsn.

Hn.

Perc.

Vln. I

Vln. II

Vla.

Vc.

Cb.

74

Fl.

Ob.

Cl.

Bsn.

Hn.

Perc.

Vln. I

Vln. II

Vla.

Vc.

Cb.

**F**

$\text{♩} = 40$

*pp*

*p*

*p*

*p*

*p*

*ppp*

gestopft

B. d.

con sordin

*pp*

*p*

*pp*

*p*

*pp*

*p*

*p*



G

♩ = 80

80

Fl. *p* *pp*

Ob. *p* *mp* *sim.*

Cl. *p* *pp*

Bsn. *sfz* *sfz* *p* *pp*

Hn. *open fiz.* *gestopft* *p* *pp*

Perc. *p* *mf* *pp* *mf* *pp* *Vibr.*

Vln. I *p* *p* *sim.*

Vln. II *p* *p* *sim.*

Vla. *p* *p* *sim.*

Vc. *p* *p* *sim.*

Cb. *senza sord.* *pizz.* *(pizz.)* *mp* *mf* *f*

H

♩ = 40

I

♩ = 80

87

Fl. *p*

Ob. *3* *5*

Cl. *p*

Bsn. *p*

Hn. *open*

Perc. *pp* *T.t. (small) arco* *(more pressure on bow)*

Vln. I *pp* *mp*

Vln. II *pp* *mp* *(sordin)*

Vla. *pp* *(sordin)*

Vc. *pp* *(sordin)*

Cb. *arco* *p* *con sordin*

8

93

Fl. *sim.*

Ob.

Cl. *sim.*

Bsn. *sim.*

Hn. *sim.*

Perc. vibr.

Vln. I *sim.*

Vln. II *sim.*

Vla. *p*

Vc. *p*

Cb. *p*

98 = 40

99 = 80

Fl. *p*

Ob. *p*

Cl. *p*

Bsn. *p*

Hn. *mp* gestopft

Perc. *mp* gongs

Vln. I *p* sul pont.

Vln. II *p* sul pont.

Vla. *p* senza sord. sul pont.

Vc. *p* senza sord. sul pont.

Cb. *mp* senza sord.

Vibr. *p* open

109

Fl. *sim.*

Ob.

Cl. *sim.*

Bsn. *sim.*

Hn. *sim.*

Perc. *Ped.*

Vln. I *sim.* 3

Vln. II *sim.* 3

Vla. *sim.* 3

Vc. *sim.* 3

Cb. *p* 3 *mf* 5

115

**L**

$\text{♩} = 40$

Fl. 3

Ob. 3

Cl. 3

Bsn.

Hn.

Perc. *T.t. (medium/big)* *mp* *Crot. arco* *p*

Vln. I 3

Vln. II

Vla. 5

Vc. 3 3

Cb. *mp*

10 122

Fl.

Ob.

Cl.

Bsn.

Hn.

Perc.

Vln. I

Vln. II

Vla.

Vc.

Cb.

128

Fl.

Ob.

Cl.

Bsn.

Vln. I

Vln. II

Vla.

Vc.